

SODOWELL 光控传感器PJ-1213-612/619-02规格书

Photo Sensor PJ-1213-612/619-02 Specifications Sheet

Spec. NO. 规格书编号: S0048A

REV.:A1 Page:1/6

版次 Rev	发出日期 Issue Date	变更内容 Revision History	制作 Issue By	复核 Checked by	批准 Approved by
A0	2019-12-14	首版 Original Release	吴恒武	---	周波
A1	2020.11.05	依客户要求PJ-1213-619-02增加插头及端子且线长加长。		---	

制品名称: 防尘遮断型光控开关

Products Name: Interrupter-Dust proof type Photo Sensor

型号: PJ-1213-612/619-02

Product Number: PJ-1213-612/619-02

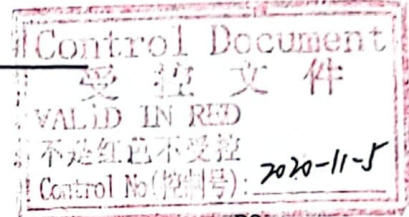

目 录

项目

- | | | |
|---|-------|--------|
| 1. 适用范围:
Scope of Applicatingns | ----- | P2 |
| 2. 绝对最大定格
Absolute Maximum Ratings | ----- | P2 |
| 3. 电气的光学特性
Electrical Optical Characteristics | ----- | P2 |
| 4. 机械特性
Mechanical Characteristics | ----- | P3 |
| 5. 内部回路图
Connection Diagram | ----- | P3 |
| 6. 部品构成表
Parts Characteristics List | ----- | P3 |
| 7. 检出位置特性(参考)
Detecting Position Characteristics (Reference) | ----- | P3, P4 |
| 8. 形状尺寸:
Outline Dimensions | ----- | P4, P5 |
| 9. 使用上的注意事项
Handing Notes | ----- | P6 |
| 10. 保证期间的保证范围
Guarantee Term And Guarantee Limits | ----- | P6 |

1. 适用范围 Scope Of Applications

本规格书适合于光控传感器PJ-1213-612/619-02.

This specification covers interrupter-Dust proof type photo sensor of PJ-1213-612/619-02.

2. 绝对最大定格 Absolute Maximum Ratings (Ta=25 °C)

项目		记号	规格	单位
Items		Symbol	Ratings	Units
发光侧 Input	直流顺电流 Forward DC Current	IF	50	mA
	直流逆电压 Reverse DC Voltage	VR	5	V
	允许损失 Power Dissipation	PD	75	mW
受光侧 Output	集电极与发射极间电压 Collector-Emitter Voltage	VCEO	30	V
	发射极与集电极间电压 Emitter-Collector Voltage	VECO	5	V
	集电极电流 Collector Current	IC	20	mA
	集电极功率损失 Collector Power Dissipation	PC	100	mW
操作温度 Operating Temperature Range		Topr	-20~+85	°C
保存温度 Storage Temperature Range		Tstg	-40~+85	°C
焊锡温度 Soldering Temperature (5 sec)		Tsol	260	°C

3. 电气光学特性 Electrical Optical Characteristics (Ta= 25 °C)

	项目 Items	符号 Symbol	测定条件 Test Conditions	最小	标准	最大	单位 Units
				Min	Typ	Max	
发光侧 Input	顺电压 Forward Voltage	V _F	I _f =20mA	—	1.2	1.5	V
	逆电流 Reverse Current	I _R	V _R =5V	—	—	100	μA
	发光波长 Peak Wavelength	λ _p	I _f =50mA	—	940	—	nm
受光侧 Output	暗电流 OFF-state Collector Current	I _{CEO}	V _{CE} =10V I _f =0mA	—	—	0.5	μA
	极限感度波长 Peak Wavelength	λ _p	—	—	800	—	nm
耦合特性 Coupled	光电流 Light Current	I _L	V _{CE} =5V I _f =20mA	0.5	—	—	mA
	集电极与发射极间饱和电压 Collector-Emitter Saturation Voltage	V _{CE(sat)}	—	—	—	0.5	V
应答时间 Switch Time	上升时间 Rise Time	t _r	V _{CC} =5V I _c =1mA R _L =1KΩ	—	400	600	μs
	下降时间 Fall Time	t _f		—	400	600	μs

应答时间测试电路 Switch Time Test Circuit

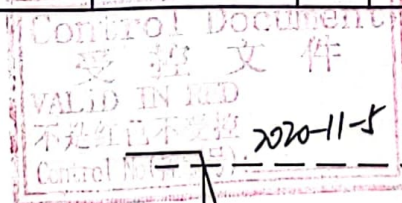
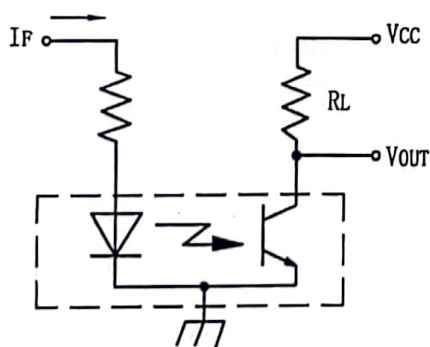

4. 机械特性 Mechanical Characteristic.

4.1 耐振动性 振幅1.5mm. 振动循环频率按10~55~10Hz, 振动周期1分钟, 反复振动测试X, Y, Z三个方向各振动2小时, 测试未发现异常。

Vibration Resistance Vibration frequency of 10~55~10Hz, 1.5mm amplitude and 1 minute sweep time in X, Y, and Z directions, each for 2 hours.

4-2. 耐冲击性 30G Max
Shock Resistance 30G Max

5. 内部接线图 Connection Diagram

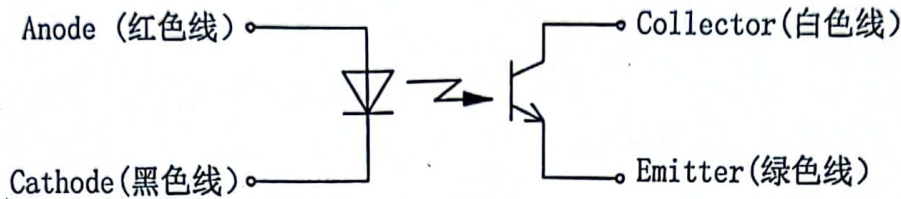

电线颜色 Wire Color	电气信号 Electric sign
红色 Red	Anode
黑色 Black	Cathode
白色 White	Collector
绿色 Green	Emitter

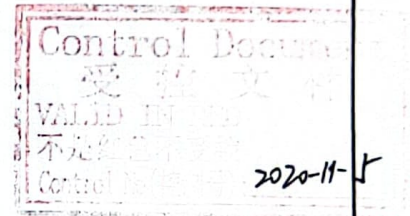

6. 部品构成 Parts List

NO.	Parts Name	Qty Used	Spec/Materials	Remarks
1	塑胶盒Case	1	PC Blue	
2	塑胶盖Cover	1	PC Blue	
3	发光素子 light emitting diode	1	---	
4	受光素子 light receiver diode	1	---	
5	金属罩 Metal shielding case	2	光槽: Slit width 0.5mm	
6	连线插头 Connector	1	UL1061 AWG24 颜色: 红/黑/绿/白.	

7. 检知位置特性 (参考) Detecting Position Characteristics (Reference)
检出位置特性 (1) Detecting Position Characteristics (1)

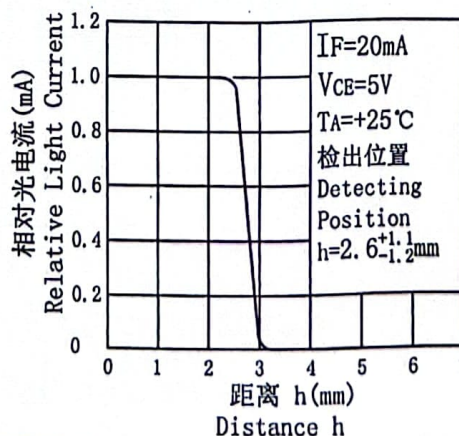
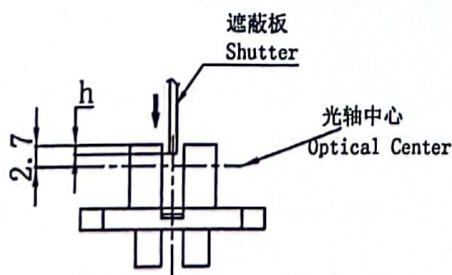

检出位置特性 (2)
Detecting Position Characteristics (2)

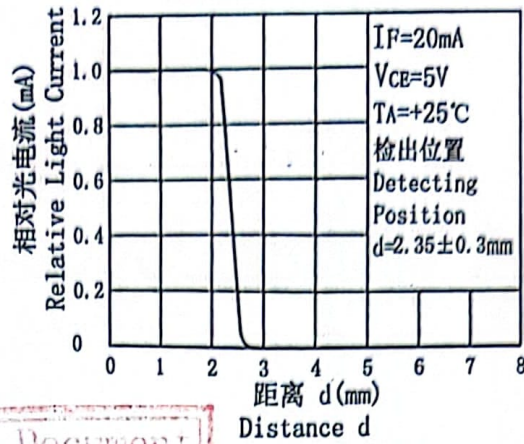
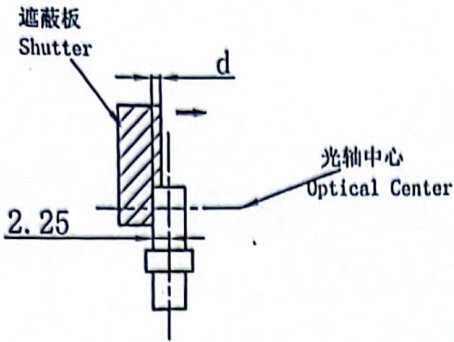

8. 外形尺寸图 Outline Dimensions

Control Document
受控文件
不是红色不受控
Control No. (控制号): 2020-11-5

单位 (Unit): mm
公差 (Tolerance): ±0.3
比例 (Scale): NIL

产品型号: PJ-1213-612-02

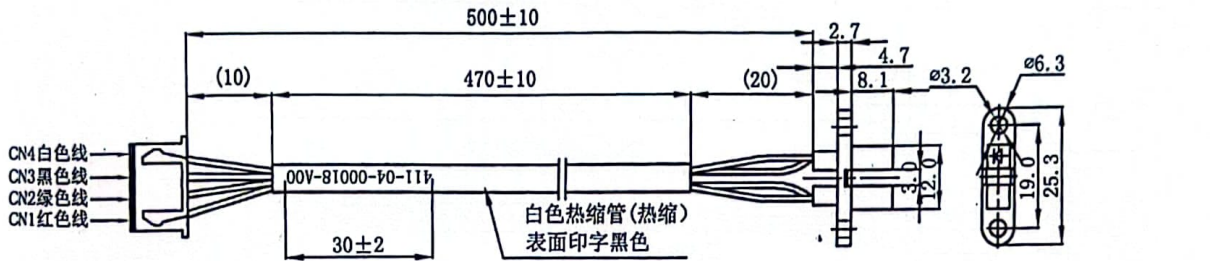

产品型号: PJ-1213-613-02

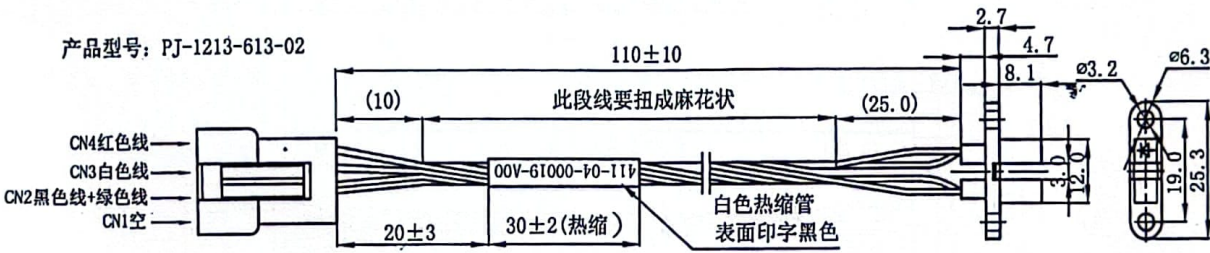

产品型号: PJ-1213-614-02.

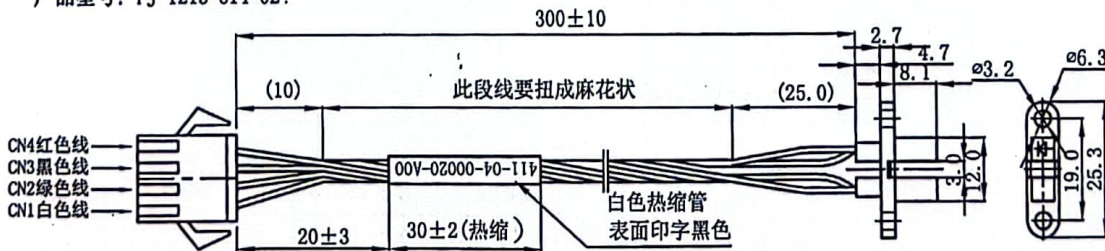

产品型号: PJ-1213-615-02

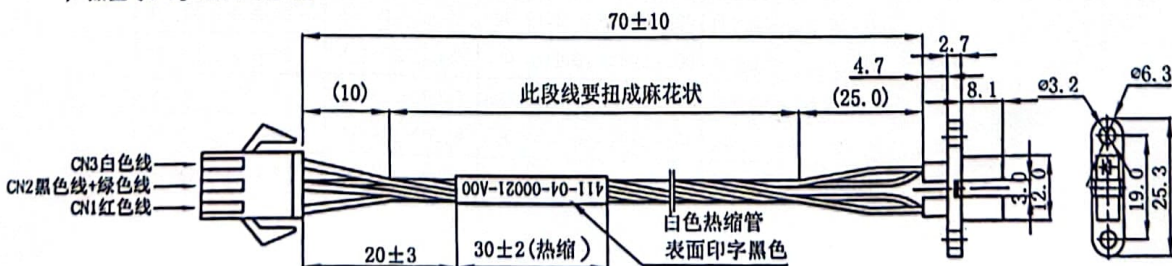

产品型号: PJ-1213-616-02

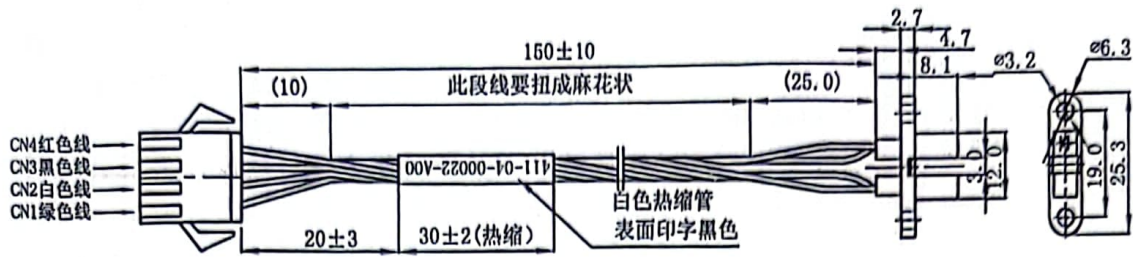

产品型号: PJ-1213-617-02

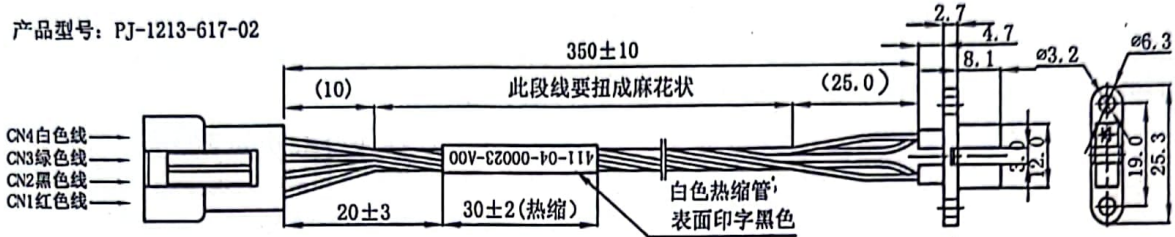

产品型号: PJ-1213-618-02

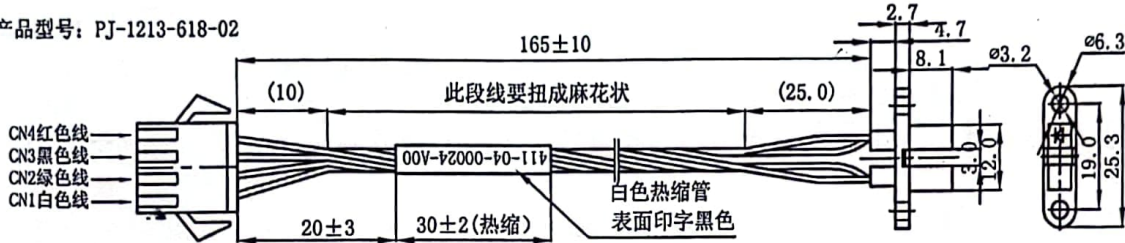

产品型号: PJ-1213-619-02

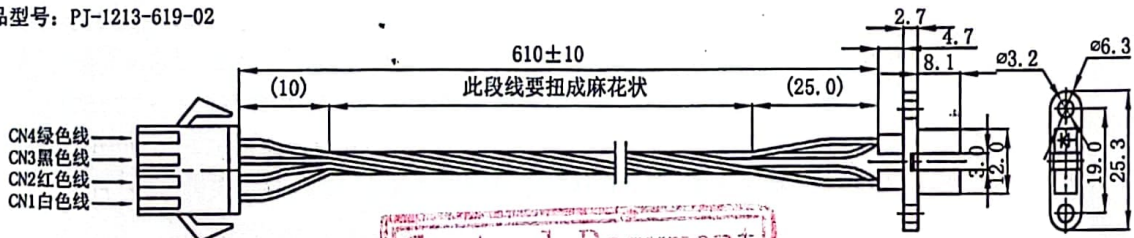

Control Document
受控文件
VALID IN RED
不是红色不受控
Control No(控制号): 2020-11-5

序号	产品型号	客户零件号	版本	套管印字内容	插头型号	线长 (mm)	备注
1	PJ-1213-612-02	411-04-00018	A00	411-04-00018-A00	JST:XHP-4 白色	500	
2	PJ-1213-613-02	411-04-00019	A00	411-04-00019-A00	JST:SMR-04V-B 黑色	110	
3	PJ-1213-614-02	411-04-00020	A00	411-04-00020-A00	JST:SMP-04V-BC 黑色	300	
4	PJ-1213-615-02	411-04-00021	A00	411-04-00021-A00	JST:SMP-03V-BC 黑色	70	
5	PJ-1213-616-02	411-04-00022	A00	411-04-00022-A00	JST:SMP-04V-BC 黑色	150	
6	PJ-1213-617-02	411-04-00023	A00	411-04-00023-A00	JST:SMR-04V-B 黑色	350	
7	PJ-1213-618-02	411-04-00024	A00	411-04-00024-A00	JST:SMP-04V-BC 黑色	165	
8	PJ-1213-619-02	411-04-00025	A01	无白色热缩管	JST:SMP-04V-BC 黑色	610	

9. 使用时注意事项:

Handling Notes

- (1). 制品在使用时要小心不能负重, 避免变形.

Careful attention should be made to avoid deformation of components.

- (2). 保存和使用要在通风良好的环境, 防有腐蚀或硫化物及潮湿空气中.

Environmental air must be free from corrosive gasses such as hydrogen sulfide or salt water air.

- (3). 使用时避免阳光直射和强光直射.

Mount sensor away from direct sun-light and incandescent.

- (4). 光发射和接收部分的表面应保护好.

The side with emitting &receiving elements should be handled very carefully.

- (5). 插头插入或拔出要在常温下进行.

Insert &remove connectors at room temperature only.

- (6). 长时间使用的情况下, 请要考虑发光素子功能的下降.

Degrading led radiant power should be addressed if sensor is used repeatedly over long period of time.

- (7). 本制品不能自动装配和焊接.

This product can not automatic mounting and automatic soldering.

- (8). 本制品应用在以下机械及设备之中。OA机器、AV机器、家电制品、通信机器(端末)、计测机器、电算机器。

This product was designed for use in the following applications.

OA equipment, video equipment, consumer electronics, communication equipment, Measuring equipment and control equipment.

10. 保证期间的保证范围

Guarantee term and guarantee limits

- (1) 保证期间 Guarantee term

交付后保证期为1年 The guarantee period is one year after the delivery date.

- (2) 保证范围 Guarantee limits

保证期内若本制品发生故障, 我们将会更换新产品, 但不负责交货后产品组合以后发生的不良。

We will replace a product if the failure is due to our manufacturing process Within the warranty term. we don not guarantee responsibility of damage by Trouble of a product after the delivery.

- (3) 本制品在使用时请注意其相关最大规格值, 若因超出其参数规格值使用发生的不良, 敝司不负责。

We will not replace a product if damage is due to disregard of maximum Rating, handling notes and other specification.

