

外形尺寸:
Outline Dimension

Spec. No. S0088

单位:mm Unit: mm

公差: ±0.3 Tolerance: ±0.3

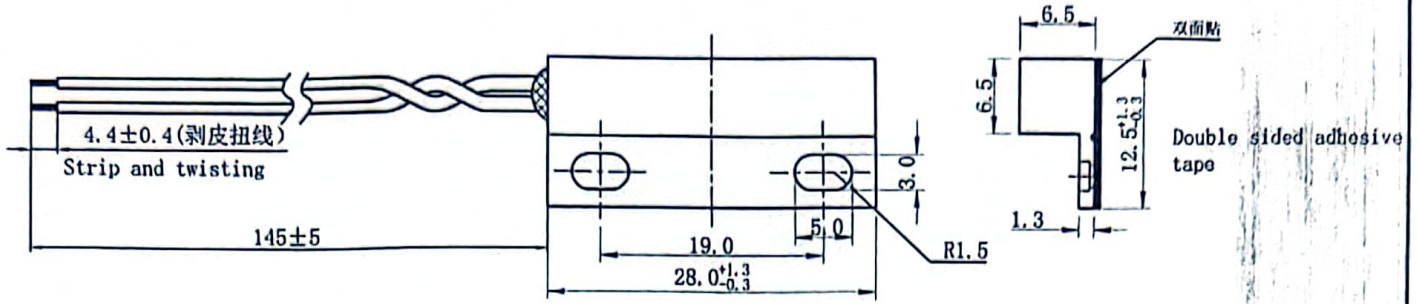

动作特性:
Operating Characteristic

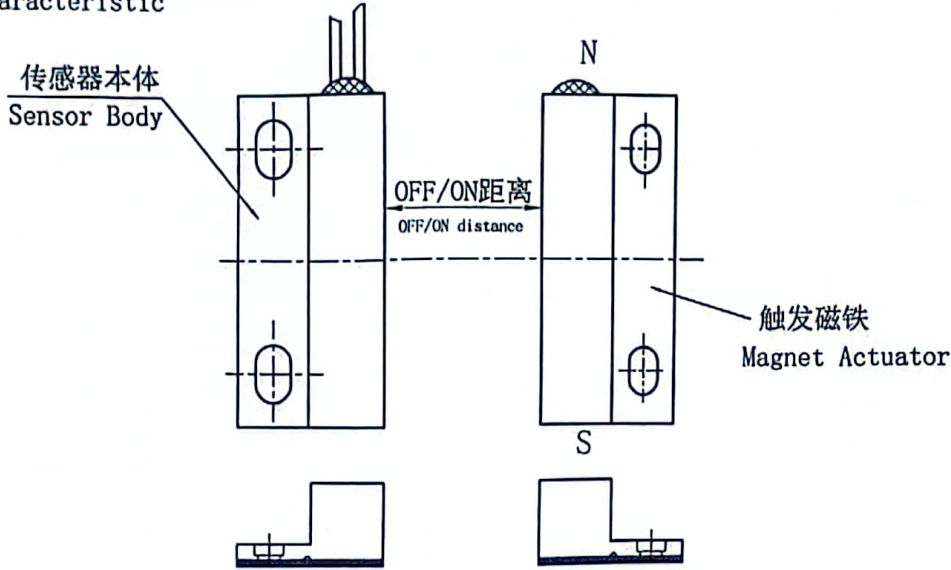

备注: NOTES

1. 传感器供应商: 兴道韦尔科技有限公司.
Sensor supplier: SODOWELL.
2. 鑫道为产品型号: PS-1301
SODOWELL P/N: PS-1301.
3. 传感器断开距离: 25mm 最小.
传感器闭合距离: 50mm 最大.
Sensor open distance is 25mm MIN.
Sensor closed distance is 50mm MAX.
4. 开关类型: 常闭型磁性开关.
Type: SPST magnetic switch (NC).
5. 最大接点容量: 5W.
MAX. contact rating: 5W.
6. 最大开关电压: DC 175V.
MAX. switching voltage DC 175V.
7. 最大开关电流: DC 0.4A.
MAX. switching current DC 0.4A.
8. 最大通电电流: DC 0.5A.
MAX. carrying current DC 0.5A.

9. 电线: UL1007 80°C 300V 22AWG 黑色.
Wire to be UL1007 80°C 300V 22AWG Black.
10. 电线末端剥皮: 4.5mm
Strip back wire leads 4.5mm.



Rev.	Date	Revision History	Issue by	Approved	DRAWN: DATE: CHECKED: DATE:	DATE: DATE:	PART NAME: Proximity Sensor	ANGLE OF VIEW
A2	2024.05.23	线束端剥皮由4.5±1变更为4.4±0.4mm	Wulw	Wulw		23/5/2024	PART NO. PS-1301	UNIT: mm SCALE: 1:1
A1	2021.03.30	Modify outline dimension tolerance, 28.0±0.3→28.0±0.1, 12.5±0.3→12.5±0.1	Wulw	Wulw			DWG. NO.	SHEET: 1 of 1
A0	2021.03.15	Original release	Wulw	Wulw		2024-5-24		DWG. SIZE: A4