

MODEL SS3 A/C CONDENSATE PAN OVERFLOW SWITCH

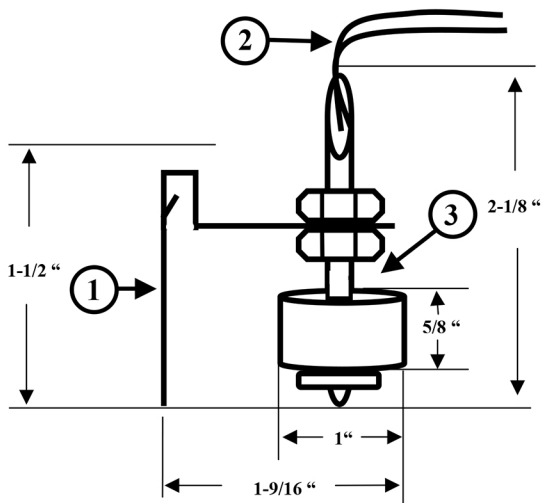

- ① Stainless Steel Clip/Bracket
- ② 72"-Inch, 18AWG Cables (Pre-wired/ Potted)
- ③ Electrically Potted Reed/Magnet Switch Assembly

COMMENTS / REQUIREMENTS:

- Minimum Pan Depth: 1-1/2 Inch. Adjusts for deeper pans
- Sensitivity: 1/4-inch rise in float opens switch
- Potted, water sealed reed/magnet switch design
- 1.25 Amp carry capacity
- 24 Volts A/C Class 2

INSTALLATION INSTRUCTIONS

NOTICE: Failure to read and comply with all warnings, cautions and instructions prior to starting installation may cause personal injury and/or property damage and void the warranty.

AUXILIARY DRAIN PAN INSTALLATION (see Figs. 1):

1. Disconnect power to unit at main panel.
2. Clip switch bracket onto side of pan at low end and press firmly into place, ensuring switch wires are positioned up. Ensure float moves freely.
3. Assure float switch assembly is firmly secured to the bracket. Ensure that top of float is below the rim of the pan. Switch will trip when water level reaches a point even with top of float (when float is in down position.) Sensitivity can be adjusted by threading the switch assembly downward out of the bracket.
4. Wire switch as instructed under Wiring, below.
5. Test switch by lifting float with unit on. Unit should stop running if switch is properly wired.
6. Test switch sensitivity: Fill pan and confirm that the switch stops the unit before the pan overflows.
7. Affix warning sticker to air handler or condenser unit.

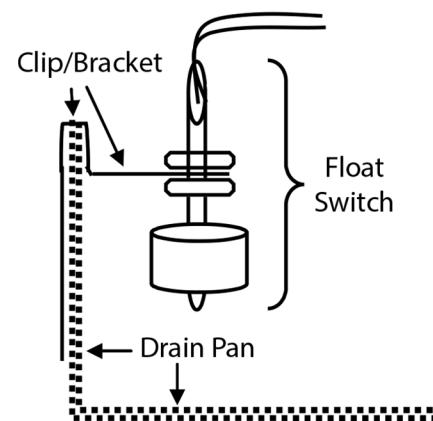

Figure 1: Installation on drain pan

WIRING (see fig. 2)

1. **WARNING:** Disconnect power to unit at main panel prior to performing electrical work.
2. If not present, it is recommended that an inline fuse be installed to protect 24-volt circuit and time delay to avoid rapid cycling of equipment.
3. Locate 24-volt thermostat cable entering the air handler unit.
4. Disconnect or cut the red wire and connect to switch lead using wire nut. Connect other switch lead to air handler terminal. Incorporating switch in red circuit shuts down entire unit. If placed in the yellow circuit, fan continues to run (inhibits mold during long absences.)
5. Test switch by lifting float while unit is running. If wired correctly, unit will stop when float is lifted.

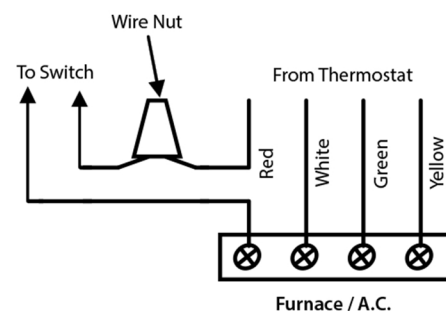

Figure 2: Wiring Diagram for Unit Shutdown

WARNING: This device must be installed strictly in accordance with manufacturer's instructions (to ensure proper operation) and in accordance with all applicable local plumbing, drainage and electrical codes.

WARNING: Electric shock hazard. Disconnect power supply before installing this product to avoid electrical shock and/or equipment damage. Use in Class 2 (thermostat) circuit only, not to exceed 24-volts, 1.25 amps to avoid damage or fire hazard.

CAUTION: If not present, it is recommended that a fuse and time delay be installed, to protect the 24-volt circuit and avoid rapid cycling of equipment, prior to installing this product.

CAUTION: This product is intended for use in water only. Not for use in the presence of flammable liquids or vapors.

CAUTION: Refer to the appropriate HVAC equipment operation manual prior to installing this product.

CAUTION: Do not use on dual compressor systems.