

MODEL SS2 3/4" CLOSE COUPLED CONDENSATE DRAIN PAN OVERFLOW KIT

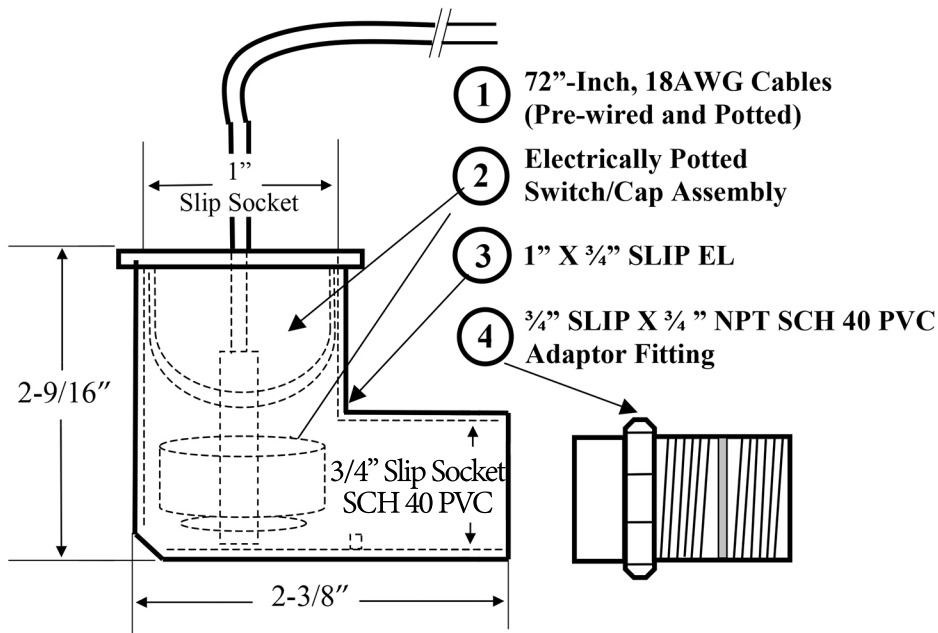

COMMENTS / REQUIREMENTS:

- Potted, electrically water sealed reed/magnet switch design.
- Schedule 40 PVC plastic components
- 24 VAC.
- 1.25 Amp carry capacity.

INSTALLATION INSTRUCTIONS

NOTICE: Failure to read and comply with all warnings, cautions and instructions prior to starting installation may cause personal injury and/or property damage and void the warranty.

AUXILIARY DRAIN OUTLET INSTALLATION:

1. Disconnect power to unit at main panel and glue 3/4" stub onto drain pan outlet adapter.
2. Ensure switch assembly is inserted into 1" inlet of PVC elbow so that float stem is at inside (bottom) of switch elbow. Float stem can be adjusted by threading it out of plug assembly. DO NOT GLUE.
3. Plumb 3/4" inlet of PVC elbow to stub as close to drain outlet as possible, ensuring that stub does not interfere with switch float. Position switch level with or below outlet. Switch may be angled up to 20° by rotating it on stub.
4. Wire switch as instructed under Wiring, below.
5. Test all fittings/connections for plumbing leaks.
6. Test switch by lifting float with unit running. Unit should stop running if correctly wired.
7. Test switch sensitivity: Plug drain downstream from installation point and run unit to fill pan. Float should rise and unit should stop before pan overflows. If the pan overflows, check that the float stem is at the inside bottom of the elbow and, if necessary, reposition entire assembly so that switch is below or angled down from the pan outlet.
8. Affix warning sticker on air handler or condenser unit.

INLINE INSTALLATION FOR (WALL) UNITS WITH VERTICAL DRAIN OUTLETS (see Fig. 1)

NOTE: It is recommended that this device be installed on the primary drain line between the pan outlet and P-Trap on wall units with vertical drain outlets (such as First Company® and Janitrol®). This will prevent the switch from shutting off the fan coil or activating the alarm circuit in the event condensate drips directly from the coil into the auxiliary pan outlet when the coil becomes dirty.

1. Disconnect power to unit at main panel and glue 5" stub down from the primary pan outlet.
2. Glue 3/4" Tee to bottom of stub with Tee stem horizontal & plumb.
3. Glue 3/4" stub into horizontal outlet of Tee, ensuring it is also plumb.
4. Ensure switch/plug assembly is inserted into 1" inlet of PVC elbow so that float stem is at inside (bottom) of switch elbow. Float stem can be adjusted by threading it out of plug assembly. DO NOT GLUE.

5. Glue drain line with P-Trap onto remaining outlet of Tee.
6. Wire switch as directed under Wiring, below.
7. Test switch by lifting float with unit running. Unit should stop running if correctly wired.
8. Test all fittings and connections for plumbing leaks.
9. Affix warning sticker on air handler or condenser unit.

Typical Wall Unit
View upward from bottom and back of unit
3.25" Minimum space required to
remove float switch

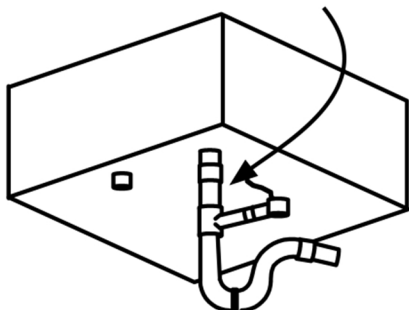

Figure 1: Vertical Drain Outlet Installation

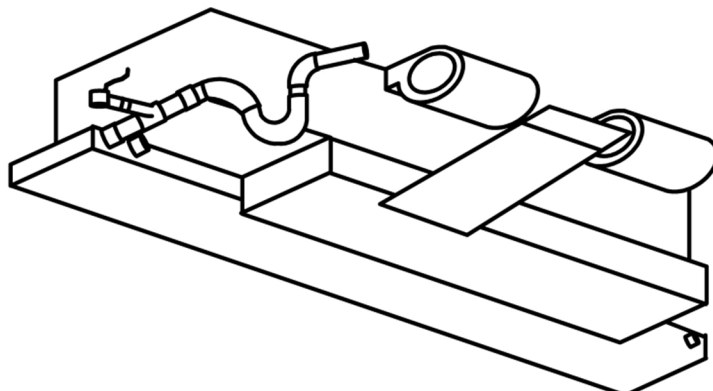

Figure 2: Horizontal Ceiling ("Pancake") Units

INLINE INSTALLATION FOR HORIZONTAL CEILING (PANCAKE) UNITS (See Fig. 2)

NOTE: Primary drain (inline) installation is also recommended on First Company® horizontal ceiling (pancake) units as some flooding may occur if installed on auxiliary outlets, due to the closeness of the outlet to the top of the pan.

1. Glue $\frac{3}{4}$ " stub to primary pan outlet.
2. Glue $\frac{3}{4}$ " Tee onto stub with Tee stem positioned horizontally away from the unit and plumb.
3. Follow steps 3-9 under INLINE INSTALLATION FOR WALL UNITS, above.

WIRING (see fig. 3)

1. **WARNING:** Disconnect power to unit at main panel prior to performing electrical work.
2. If not present, it is recommended that an inline fuse be installed to protect 24-volt circuit and time delay to avoid rapid cycling of equipment.
3. Locate 24-volt thermostat cable entering the air handler unit.
4. Disconnect or cut the red wire and connect to switch lead using wire nut. Connect other switch lead to air handler terminal. Incorporating switch in red circuit shuts down entire unit. If placed in the yellow circuit, fan continues to run (inhibits mold during long absences.)
5. Test switch by lifting float while unit is running. If wired correctly, unit will stop when float is lifted.

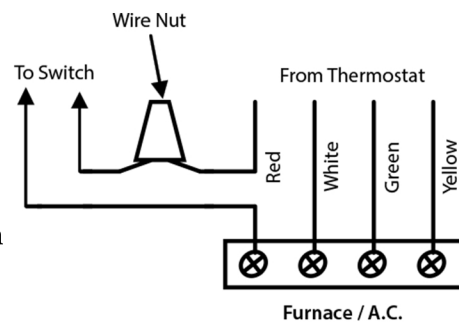

Figure 3: Wiring Diagram for Unit Shutdown

WARNING: This device must be installed strictly in accordance with manufacturer's instructions (to ensure proper operation) and in accordance with all applicable local plumbing, drainage and electrical codes.

WARNING: Electric shock hazard. Disconnect power supply before installing this product to avoid electrical shock and/or equipment damage. Use in Class 2 (thermostat) circuit only, not to exceed 24-volts, 1.25 amps to avoid damage or fire hazard.

CAUTION: This device will not detect clogs occurring upstream from the installation point.

CAUTION: If not present, it is recommended that a fuse and time delay be installed, to protect the 24-volt circuit and avoid rapid cycling of equipment, prior to installing this product.

CAUTION: When installing this device in plugged configuration on auxiliary drain outlets, it is essential that PVC plug is closed off and water-tight.

CAUTION: This product is intended for use in water only. Not for use in the presence of flammable liquids or vapors.

CAUTION: Refer to the appropriate HVAC equipment operation manual prior to installing this product.

CAUTION: Do not use on dual compressor systems.