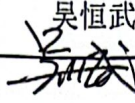
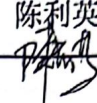

SODOWELL 光控传感器TPJ-6301-01规格书

Photo Sensor TPJ-6301-01 Specifications Sheet

Spec. NO. 规格书编号: S0134

REV.:A Page:1/4

版次 Rev	变更内容 Revision History	发出日期 Issue Date	制作 Lssue By	复核 Checked by	批准 Approved by
A	首版 Original Release	2022-02-28	吴恒武 	---	陈利英 

制品名称: 管液检测型光电传感器

Products Name: Tube Liquid type Photo Sensor

型 号: TPJ-6301-01

Product Number: TPJ-6301-01

目 录

CONTENT

项目		
1. 适用范围:	-----	P2
Scope of Applicatingns		
2. 绝对最大定格	-----	P2
Absolute Maximum Ratings		
3. 电气的光学特性	-----	P2
Electrical Optical Characteristics		
4. 机械特性	-----	P2
Mechanical Characteristics		
5. 内部回路图	-----	P3
Connection Diagram		
6. 接线表	-----	P3
Wire Connection Table		
7. 形状尺寸:	-----	P3
Outline Dimensions		
8. 使用上的注意事项	-----	P4
Handing Notes		
9. 保证期间的保证范围	-----	P4
Guarantee Term And Guarantee Limits		

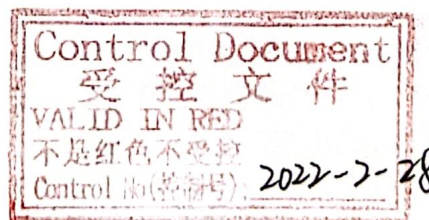

1. 适用范围 Scope Of Applications

本规格书适合于管液检测型光控传感器TPJ-6301-01.

This specification covers tube liquid type photo sensor TPJ-6301-01.

2. 绝对最大定格 Absolute Maximum Ratings (Ta=25°C)

项目		记号	规格	单位
Items		Symbol	Ratings	Units
发光侧 Input	直流顺电流 Forward DC Current	IF	50	mA
	直流逆电压 Reverse DC Voltage	VR	5	V
	允许损失 Power Dissipation	Pd	75	mW
受光侧 Output	集电极与发射极间电压 Collector-Emitter Voltage	VCE0	30	V
	发射极与集电极间电压 Emitter-Collector Voltage	VECO	5	V
	集电极电流 Collector Current	IC	20	mA
	集电极功率损失 Collector Power Dissipation	PC	100	mW
操作温度 Operating Temperature Range		Topr	-20~+85	°C
保存温度 Storage Temperature Range		Tstg	-40~+85	°C

3. 电气光学特性 Electrical Optical Characteristics (Ta= 25 °C)

	项目 Items	符号 Symbol	测定条件 Test Conditions	最小	标准	最大	单位 Units
				Min	Typ	Max	
发光侧 Input	顺电压 Forward Voltage	VF	If=20mA	-	1.2	1.5	V
	逆电流 Reverse Current	IR	VR=5V	-	-	100	µA
	发光波长 Peak Wavelength	λp	If=50mA	-	940	-	nm
受光侧 Output	暗电流 OFF-state Collector Current	ICE0	VCE=10V If=0mA	-	-	0.5	µA
	集电极与发射极间饱和电压 Collector-Emitter Saturation Voltage	VCE(sat)	-	-	-	0.5	V
耦合特性 Coupled	空管光电流 (1*) Empty Tube Light Current	IC	VCC=5V VCE=5V	-	-	(2.0)	mA
	满水光电流 (1*) Full Water Light Current	IC	VCC=5V VCE=5V	(4.0)	-	-	mA

(1*): Tubing — Transparent NE-9550 material. OD=6.35mm.

4. 机械特性 Mechanical Characteristic.

4.1 耐振动性 振幅1.5mm. 振动循环频率按10~55~10Hz, 振动周期1分钟, 反复振动测试X, Y, Z三个方向各振动2小时, 测试未发现异常。

Vibration Resistance

Vibration frequency of 10~55~10Hz, 1.5mm amplitude and 1 minute sweep time in X, Y, and Z directions, each for 2 hours.

4-2. 耐冲击性

Shock Resistance

294m/S² (30G) 以上。

294m/S² (30G) or more.

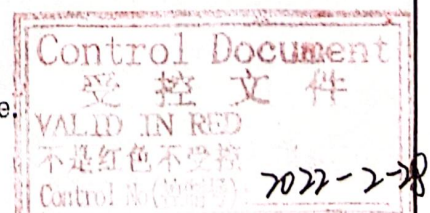

5. 内部接线图 Connection Diagram

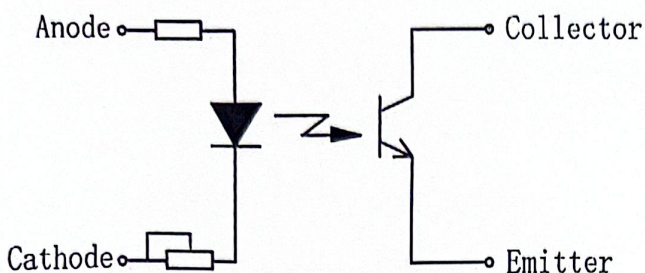

6. 接线表 Connection Table

电线颜色 Wire Color	电气信号 Electric sign
红色 Red	Anode
黑色 Black	Cathode
白色 White	Collector
绿色 Green	Emitter

7. 外形尺寸图 Outline Dimensions

单位(Unit): mm
比例 (Scale): 1:1
一般公差: ±0.3
Tolerance: ±0.3

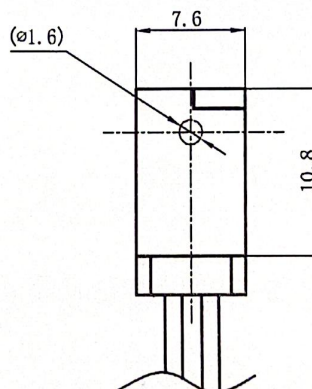
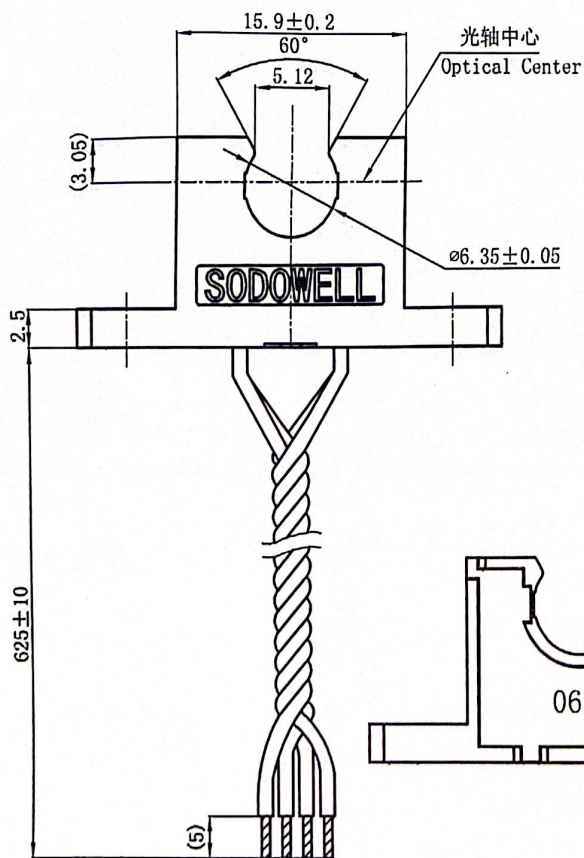
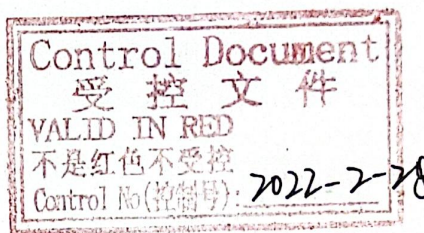
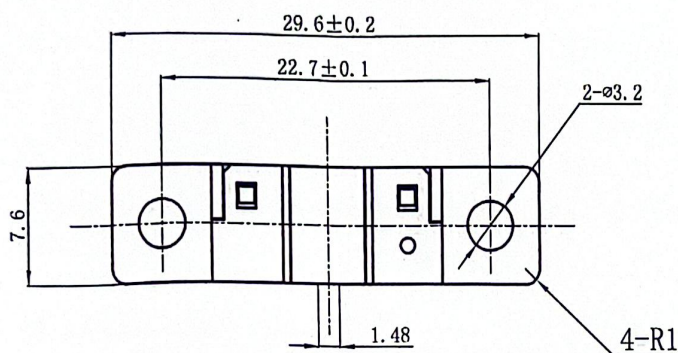

产品 Lot No. 镭雕
Lot No. marking
laser carving

Lot No. 说明:

- 0623
- └─ 制作日: 用2位数表示。即01~31。
 - └─ 制作月: 用1位数表示。
 - 1月 --- 1
 - 2月 --- 2
 - ...
 - 10月 --- X
 - 11月 --- Y
 - 12月 --- Z
 - └─ 制作年: 公历年最后一位。
例: 2020年用0表示。

8. 使用时注意事项:

Handling Notes

- (1). 制品在使用时要小心不能负重, 避免变形。

Careful attention should be made to avoid deformation of components.

- (2). 保存和使用要在通风良好的环境, 防有腐蚀或硫化物及潮湿空气中。

Environmental air must be free from corrosive gasses such as hydrogen sulfide or salt water air.

- (3). 使用时避免阳光直射和强光直射。

Mount sensor away from direct sun-light and incandescent.

- (4). 光发射和接收部分的表面应保护好。

The side with emitting &receiving elements should be handled very carefully.

- (5). 插头插入或拔出要在常温下进行。

Insert &remove connectors at room temperature only.

- (6). 不要用洗净剂清洗传感器, 洗净剂残留有可能会对传感器造成损坏。如必须要清洁传感器表面请用蘸有洗净液比如酒精的软布进行清洁。

Do not wash sensor, Liquid may get into the case and cause damage. If you must clean the surface area use a soft cloth damped with a washing fluid such as Ethanol.

9. 保证期间的保证范围

Guarantee term and guarantee limits

- (1) 保证期间 Guarantee term

交付后保证期为1年 The guarantee period is one year after the delivery date.

- (2) 保证范围 Guarantee limits

保证期内若本制品发生故障, 我们将会更换新产品, 但不负责交货后产品组合以后发生的不良。

We will replace a product if the failure is due to our manufacturing process Within the warranty term. we don not guarantee responsibility of damage by Trouble of a product after the delivery.

- (3) 本制品在使用时请注意其相关最大规格值, 若因超出其参数规格值使用发生的不良, 敝司不负责。

We will not replace a product if damage is due to disregard of maximum Rating, handling notes and other specification.

